







F.P.T. HAND PUMPS from 700 to 4.000 bar

F.P.T. manufactures a wide range of high pressure hand pumps, available in multiple configurations with different tank capacities, valves, construction's materials and types of fluid to be pumped. High performance, easy to use and toughness are the characteristics that distinguish them.



INDEX HAND PUMPS

	Oil tank capacity (litres)	cm ³ /stroke	Series		
Single speed	0,7 - 4	3	PMSA		54
Two speed	1 - 9	122 - 4,8	PDSA		56
Two speed for double acting cylinder	1,8 - 9	122 - 4,8	PDSA DE		58
Very high pressure 1600 - 3000 - 4000 bar	1,8	40 - 1	PMSA- PDSA		60
For diversified utilizations – stainless steel made	0,5 - 2	36,2	PS-PSS		62
Hand pumps for use with water	1,8	40 - 3	PDSA-40H ₂ O		64

PAGE

F.P.T. HAND PUMPS

High pressure hand pumps produced in light aluminum alloy of aeronautics grade to minimize weight. Operating pressure from 700 to 4.000 bar. Used in multiple fields of application, they represent an important tool, essential wherever there is no source of energy.

ALUMINUM ALLOY OF AERONAUTICS GRADE LIGHTWEIGHT AND EXTREMELY TOUGH

The use of this type of material reduces weights of the pump and the fatigue of the operator to their lowest increasing the handling and portability, even in environments that are difficult to reach. Designed to withstand critical conditions of work, fast and with low effort on the lever. The ideal tool.

CUSTOM HAND PUMPS ON CUSTOMER'S REQUEST

On request:

- Viton - Ethylene propylene special gaskets
- Various oiltank capacities available
- Customizable with additional relief valves.
- For hydrostatic tests with fluids different from oil.
- Dimensions, fixing holes, valve blocks to customer specification.

Tough pins with trough-holes for fixing to machinery or structures.

Oil filler cap with integrated vent

Surface treatments to guarantee total reliability in the most difficult environments and the maximum duration.

Designed to have high performance, maintaining optimal effort on the lever.

Lever locking system for easy and better portability.

Pressure gauge connection integrated that allows the direct assembly of the measuring instrument.

Low weight and excellent ergonomics. Heavy duty design.

Pressure relief valve integrated in the pump body for top operator's safety.

Equipped with an ergonomic bypass handle in techno polymer for the controlled pressure relief.

Two-stage models with very high flow at low pressure for the maximum speed during operations.

H2O HAND PUMPS – WATER FLUID USE



FPT produces a range of hand pumps that can be used with water. This choice is a solution that protects the environment and can be used anywhere as the water is an eco-friendly fluid. It can therefore be operated in any environment. The H2O series is very popular in laboratories for pressure testing, on-site tests and in all those situations where contamination with oil is not allowed.

PUMP CODE DESCRIPTION

The coding table of the hand pumps shows the various possibilities of range, choice of materials, type of drive and tank capacities available. This table, in addition to the request for costum pumps, may be useful to identify an F.P.T. hand pump in your possession and request spare parts or a new one.

PMS	A	3,5	DE	4	V
PMS – SINGLE SPEED PUMP PDS – DOUBLE SPEED PUMP PS - SINGLE PISTON	A ALLUMINIUM H₂O STAINLESS STEEL	3,5 OIL FLOW cm ³ /STROKE	DE DOUBLE ACTING FC FOOT CONTROL	4 OIL TANK CAPACITY (litres)	V VITON EP ETHYLENE PROPYLENE
					FOR SPECIAL PUMPS CUSTOMER IDENTIFICATION

PMSA

700 bar
3 cm³ oil flow
0,7 - 4 l capacity

Series
PMSA

Single speed hand pump aluminium



Compact and light weight

- High pressure hand pumps manufactured in light alloy aluminum of aeronautical grade to minimize the weight.
- Single stage version with a maximum flow rate of 3 cc per stroke suitable for single acting applications.
- Pressure relief valve integrated in the pump body for maximum operator safety.
- High performance, low weight and excellent ergonomics.
- Integrated pressure gauge connection for direct assembly of measuring instrument.
- Oil filler cap with integrated breather. Tough pins with trough-holes for attachment to machinery or structures.
- Surface treatments to guarantee total reliability in the most difficult environments and maximum duration.

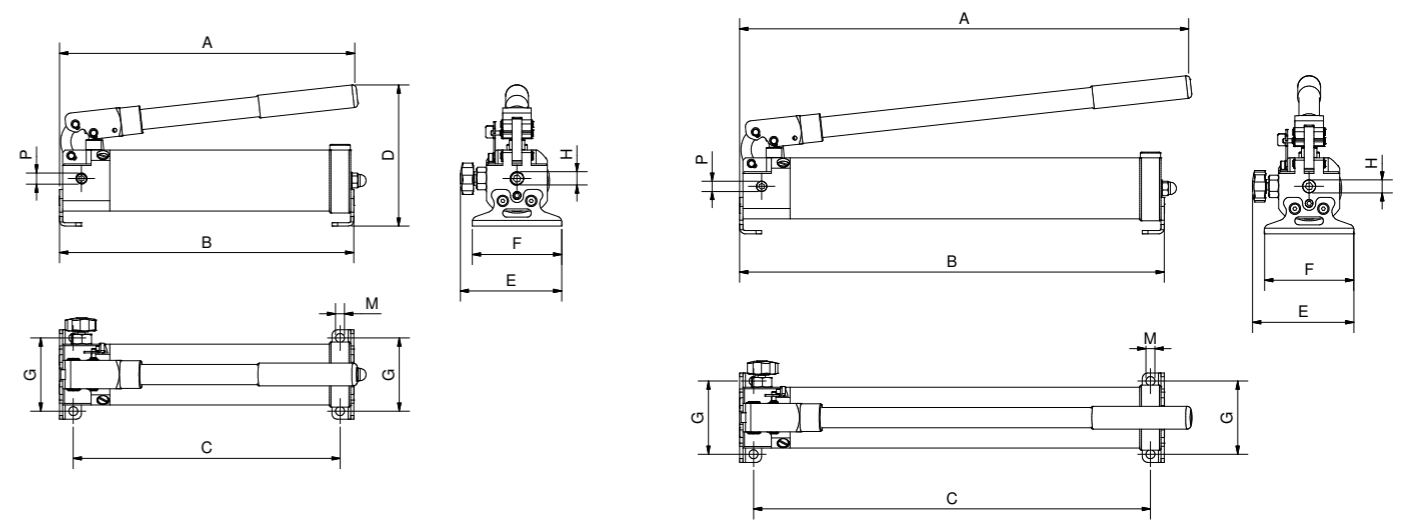

PMSA-2

PMSA-3

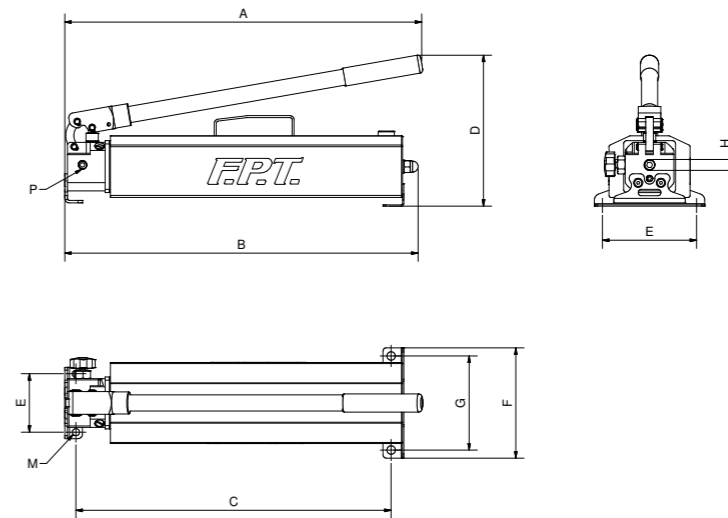

PMSA - 3/L3

CUSTOM PUMPS ON REQUEST

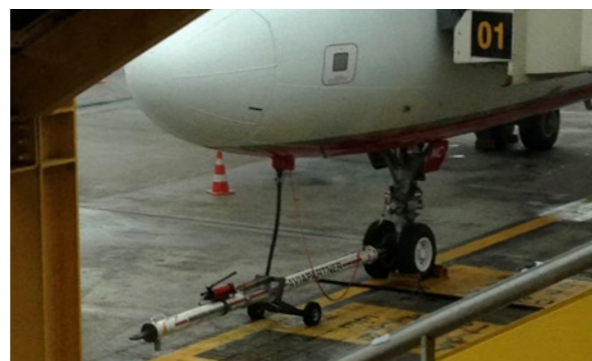
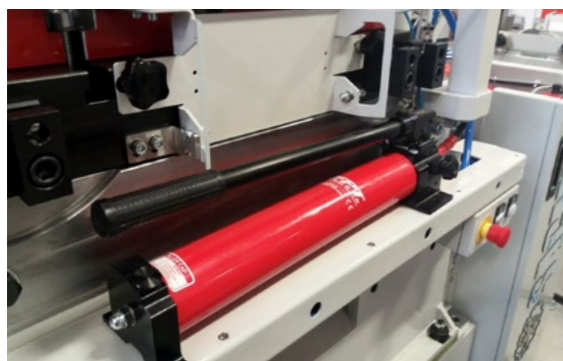

MODEL	PRESSURE max	OIL DISPLACEMENT STROKE	RESERVOIR CAPACITY	USABLE OIL	DIMENSIONS in mm										WEIGHT
					A	B	C	D	E	F	G	H	M	P	
PMSA - 2	700	2	0,7	0,5	367	362	328	175	124,5	110	90	3/8" NPT	11	1/4" NPT	3,5
PMSA - 3	700	3	1,3	1	555	522	488	195	135	110	90	3/8" NPT	11	1/4" NPT	4,6
PMSA - 3/L3	700	3	4	3	556	544	485,5	233	90	170	145	3/8" NPT	13	1/4" NPT	8,5

PDSA

700 bar
122 - 2,6 cm³ oil flow
1 - 9 l capacity

Series
PDSA

Two speed hand pump aluminium



For maximum performance

- High pressure hand pumps manufactured in light alloy of aeronautical grade aluminum to minimize the weight.
- Two speed version first stage 40 cc flow rate for rapid approach and 3 cc at the second stage. For maximum speed during operations.
- Pressure relief valve integrated in the pump body for maximum operator safety.
- High performance, low weight and excellent ergonomics.
- Integrated pressure gauge connection for direct assembly of measuring instrument.
- Oil filler cap with integrated breather. Tough pins with trough-holes for attachment to machinery or structures.
- Surface treatments to guarantee total reliability in the most difficult environments and maximum duration.

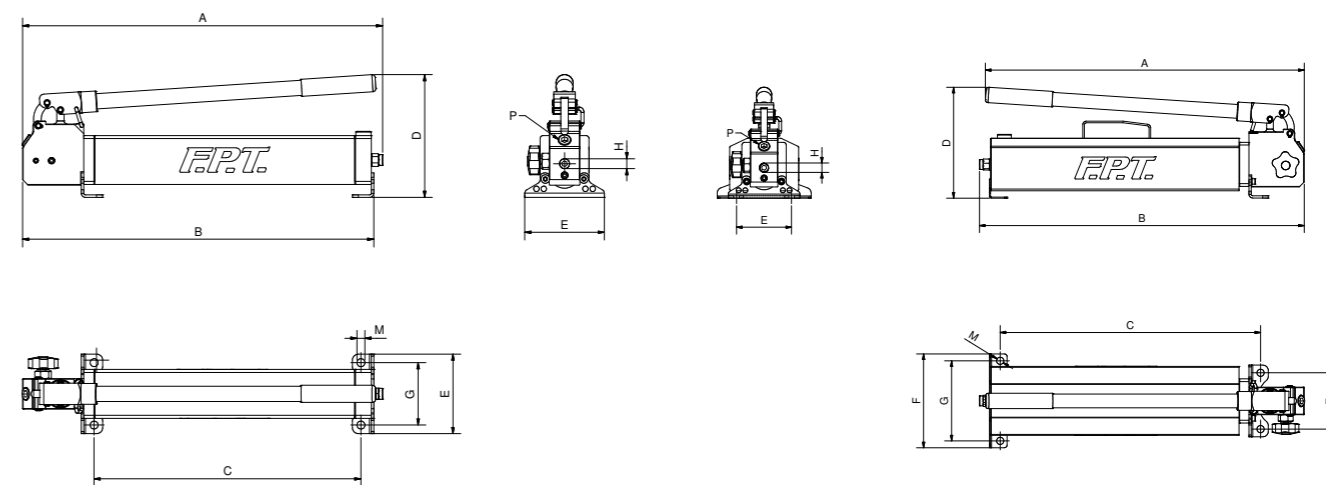

PDSA 40C - PDSA-40

PDSA-40 L4/L8

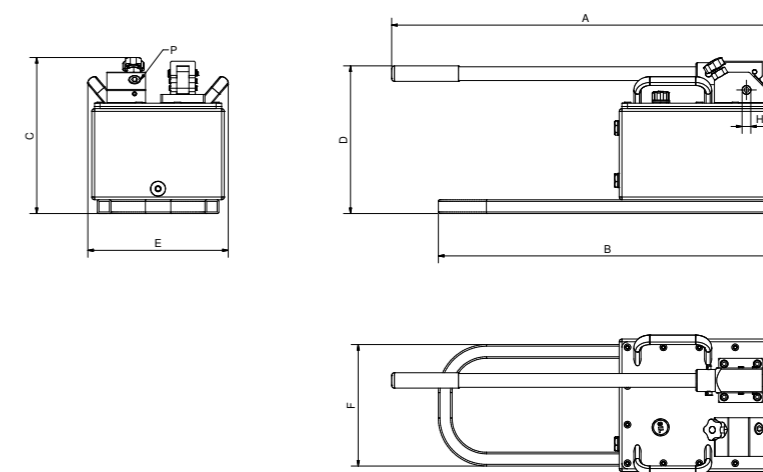

PDS-120-SE

CUSTOM PUMPS ON REQUEST



MODEL	PRESSURE 1 ST /2 ND STAGE bar	OIL FLOW 1 ST /2 ND STAGE cm ³	RESERVOIR CAPACITY litres	USABLE OIL litres	DIMENSIONS in mm										WEIGHT kg
					A	B	C	D	E	F	G	H	M	P	
PDSA-40C	25/700	40/1	1	0,9	392,5	378	240	190	130	130	102	3/8" NPT	13	G 1/2"	5,5
PDSA - 40	25/700	40/3	1,8	1,6	590	477	435	200	130	130	102	3/8" NPT	13	G 1/2"	7,8
PDSA - 40 L4	25/700	40/2,6	4	3,2	578	588	471,5	201	102	170	145	3/8" NPT	13	G 1/2"	11
PDSA - 40 L8	25/700	40/2,6	8	6,3	578	588	471,5	201	102	290	265	3/8" NPT	13	G 1/2"	16,5
PDS - 120 - SE	20/700	122/4,8	9	7,5	702	617	326	269	253	220	-	3/8" NPT	-	G 1/2"	22,5

PDSA DE

700 bar
40 - 3 cm³ oil flow
1,8 - 9 l capacity

Series
PDSA DE

Two speed hand pump aluminium, for double acting cylinders



For maximum Performance

- High pressure hand pumps manufactured in light alloy of aeronautical grade aluminum to minimize the weight.
- Double stage version for double acting cylinders, with first stage 40 cc flow rate for rapid approach and 3 cc at the second stage. For maximum speed during operations.
- Pressure relief valve integrated in the pump body for maximum operator safety.
- High performance, low weight and excellent ergonomics.
- Integrated pressure gauge connection for direct assembly of measuring instrument.
- Oil filler cap with integrated breather. Tough pins with trough-holes for attachment to machinery or structures.
- Surface treatments to guarantee total reliability in the most difficult environments and maximum duration

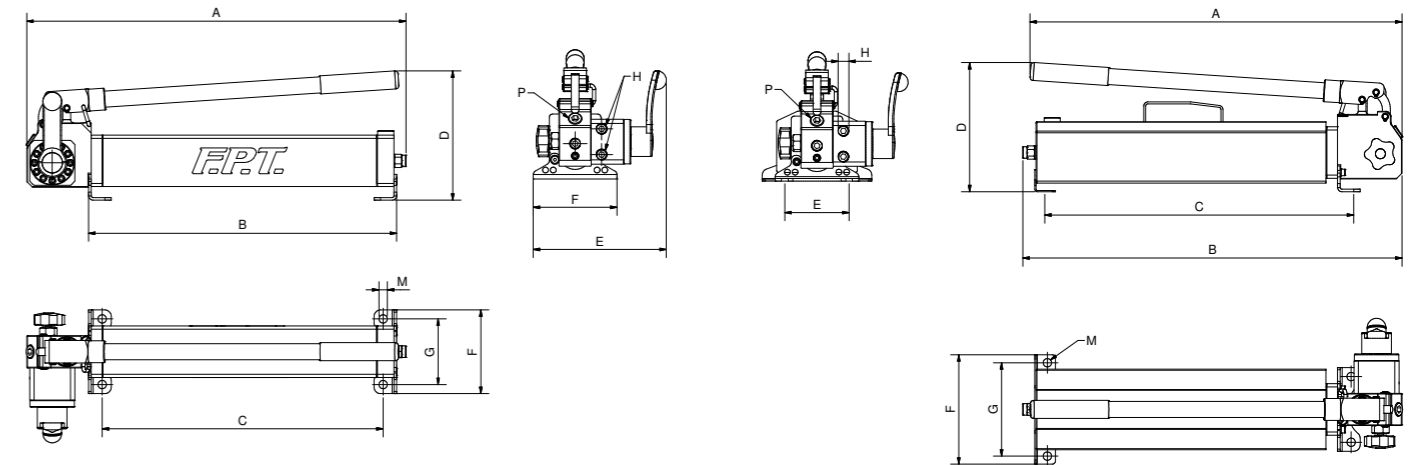

PDSA-40-DE

PDSA-40-DE L4/L8

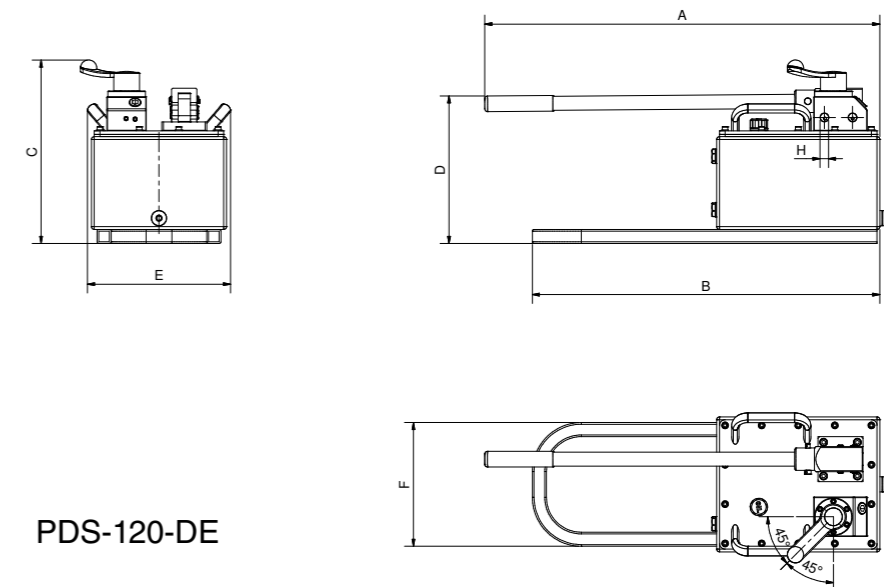

PDS-120-DE

CUSTOM PUMPS ON REQUEST



MODEL	PRESSURE	OIL FLOW	RESERVOIR	USABLE	DIMENSIONS in mm										WEIGHT
	1 ST /2 ND STAGE	1 ST /2 ND STAGE	CAPACITY	OIL	A	B	C	D	E	F	G	H	M	P	kg
PDSA-40-DE	25/700	40/3	1,8	1,6	590	477	435	200	207	130	102	3/8" NPT	13	G 1/2"	9
PDSA-40-DE L4	25/700	40/2,6	4	3,2	578	588	471,5	201	102	170	145	3/8" NPT	13	G 1/2"	12
PDSA-40-DE L8	25/700	40/2,6	8	6,3	578	588	471,5	201	102	290	265	3/8" NPT	13	G 1/2"	17,5
PDS-120-DE	20/700	122/4,8	9	7,5	702	617	326	269	253	220	-	3/8" NPT	-	G 1/2"	22,5

PMSA - PDSA

1.600 - 3.000 - 4.000 bar
1,8 l capacity

Series
PMSA - PDSA

Hand pumps for very high pressures: 1.600 - 3.000 - 4000 bar, aluminium



For very high pressure

- High pressure hand pumps manufactured in light alloy of aeronautical grade aluminum to minimize the weight.
- Two-stage versions 1.600 bar and 3.000 bar with first stage 40 cc oilflow for rapid approach and second stage 0.5 and 1 cc. And 0.5 cc per stroke 4,000 bar single-stage version.
- Pump body integrated pressure relief valve for maximum operator safety.
- Very high pressure, high performance, reduced effort on the handle, excellent weight and ergonomics.
- Integrated pressure gauge connection for direct mounting of the measuring tool.
- Oil filler cap with integrated breather. Tough pins with trough-holes for attachment to machinery or structures.
- Surface treatments to guarantee total reliability in the most difficult environments and maximum duration.

CUSTOM PUMPS ON REQUEST

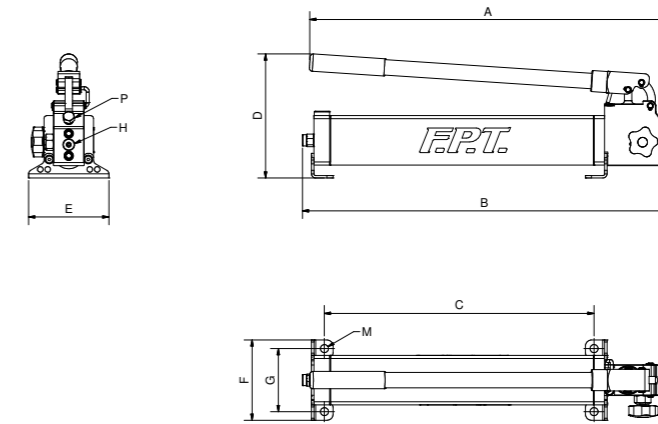

PDSA 1600 - 3000 - 4000

PUMP	MODEL	PRESSURE	OIL FLOW	RESERVOIR	USABLE	DIMENSIONS in mm										WEIGHT
		1 ST /2 ND STAGE	1 ST /2 ND STAGE	CAPACITY	OIL	A	B	C	D	E	F	G	H	M	P	
		bar	cm ³	litres	litres											kg
TWO-SPEED	PDSA-1600	25/1600	40/1	1,8	1,6	577	588,5	436	200	130	130	102	1/4" GAS	13	1/2" GAS	7,8
TWO-SPEED	PDSA-3000	16/3000	40/0,5	1,8	1,6	577	588,5	436	200	130	130	102	3/4"-16 UNF	13	9/16"-18 UNF	7,8
SINGLE-SPEED	PMS-4000	4000	0,5	1,8	1,6	577	588,5	436	200	130	130	102	9/16"-18 UNF	13	9/16"-18 UNF	7,8

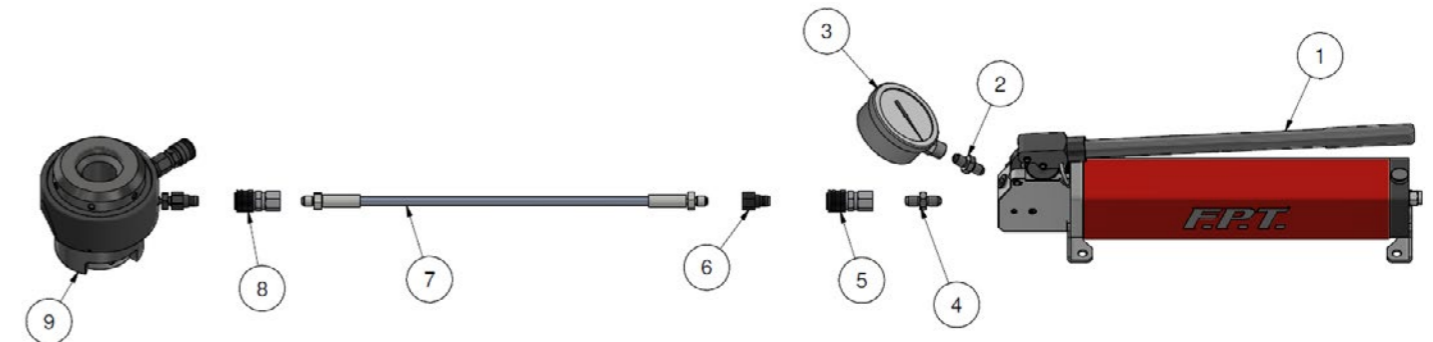

Configuration No.1 – Quick coupler on pump
Configuration No.2 – Flex hose directly assembled on the pump

	1500 Bar - Config.1	1500 Bar - Config.2	1600 Bar - Config.1	1600 Bar - Config.2	2500 Bar - Config.1	2500 Bar - Config.2	3000 Bar - Config.1	3000 Bar - Config.2	4000 Bar - Config.1	4000 Bar - Config.2
ITEM	CODE	CODE	CODE	CODE	CODE	CODE	CODE	CODE	CODE	CODE
1	01PDSA1600	01PDSA1600	01PDSA1600	01PDSA1600	01PDSA3000	01PDSA3000	01PDSA3000	01PDSA3000	01PMS4000	01PMS4000
2	-	-	-	-	0922225016	0922225016	0922225016	0922225016	0922225016	0922225016
3	01MD200G	01MD200G	01MD200G	01MD200G	01MD300G	01MD300G	01MD300G	01MD300G	01MD400G	01MD400G
4	0925613265	-	0925613265	-	09299199501611	0929112241	0922225257	09222199501606	0922225016	-
5	07GR15F	-	07GR20F	-	07GR25F	-	07GR30F	-	07GR40F-M16	-
6	07GR15M	-	07GR20M	-	07GR25M	-	07GR30M	-	07GR40M-M16	-
7	01TFR#/1800	01TFR#/1800	01TFR#/1800	01TFR#/1800	01TFR#/2500	01TFR#/2500	01TFR#/3000M16D	01TFR#/3000M16G	01TFR#/4000M16D	01TFR#/4000M16H
8	07GR15F	07GR15F	07GR20F	07GR20F	07GR25F	07GR25F	07GR30F	07GR30F	07GR40F-M16	07GR40F-M16
9	Utilization	Utilization	Utilization	Utilization	Utilization	Utilization	Utilization	Utilization	Utilization	Utilization

insert length of the hose expressed in meters.

PS-PSS

35 - 2000 bar
0,7 - 36,2 cm³ oil flow

Series
PS-PSS

Pumps for diverse utilizations from 35 to 2000 bar

For being flexible

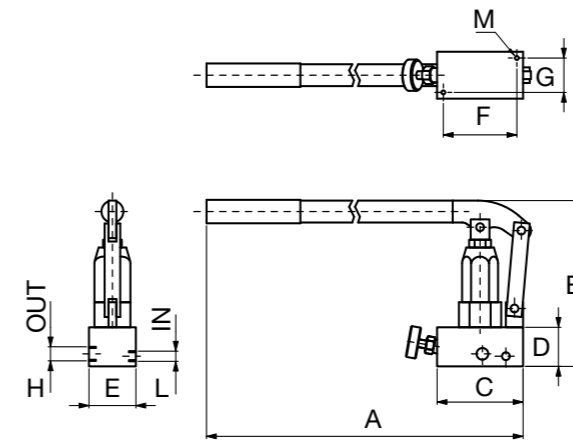
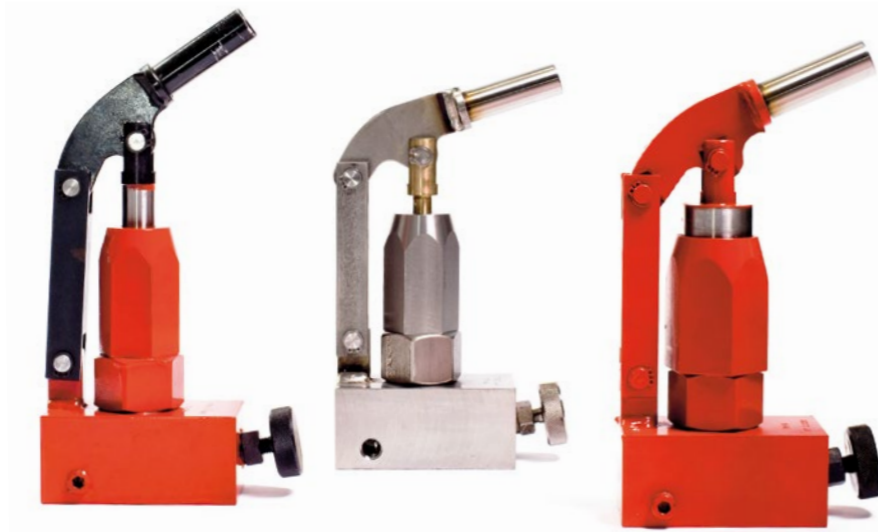

PS

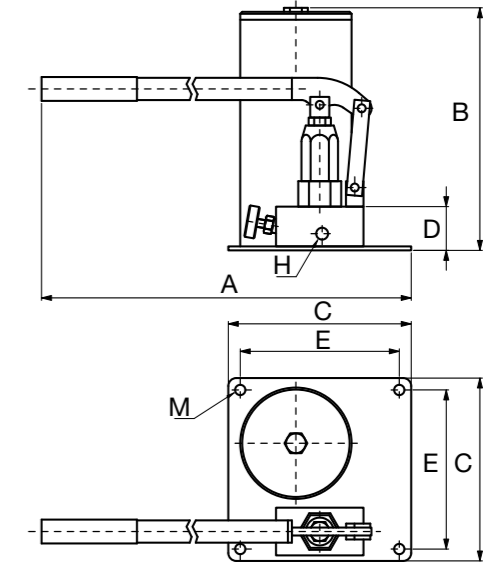

PS-L0.5/L2

- High pressure hand pump available in steel series, with or without tank (PS - PSL)
- To use with water, H2O series with body and stainless steel components available (PSS - PSSL).
- Available in different single-stage arrangements with maximum working pressure: 35 - 105 - 210 - 700 - 1400 - 2000 bar. Suitable for single acting applications.



- Equipped with a bypass handwheel for controlled discharge of the pressure
- Pumps without pressure relief valve, designed to be integrated into any existing circuit.
- Surface treatments to guarantee total reliability in the most difficult environments and maximum duration.

CUSTOM PUMPS ON REQUEST



MATERIAL	MODEL	Ø PISTON	PRESSURE	OIL FLOW	RESERVOIR CAPACITY	DIMENSIONS in mm										WEIGHT
		mm				bar	cm ³	litres	A	B	C	D	E	F	G	
STEEL	PS - 34	38	35	36,2	-	640	230	110	50	60	94	44	3/8" NPT	1/4" GAS	M8	7
STEEL	PS - 17	26	105	17,87	-	640	230	110	50	60	94	44	3/8" NPT	1/4" GAS	M8	5,7
STEEL	PS - 9	19	210	9,92	-	640	230	110	50	60	94	44	3/8" NPT	1/4" GAS	M8	5,3
STEEL	PS - 3,6	12	700	3,92	-	640	230	110	50	60	94	44	3/8" NPT	1/4" GAS	M8	5,3
STEEL	PS - 2,5	9,5	1400	2,6	-	640	230	110	50	60	94	44	3/8" NPT	1/4" GAS	M8	5,3
STEEL	PS - 0,7	7	2000	0,7	-	640	230	110	50	60	94	44	1/4" GAS	1/4" GAS	M8	5,3
STEEL	PS - 34 / L2	38	35	36,2	2	700	310	230	70	200			3/8" NPT		13	12
STEEL	PS - 17 / L2	26	105	17,87	2	700	310	230	70	200			3/8" NPT		13	10,7
STEEL	PS - 9 / L2	19	210	9,92	2	700	310	230	70	200			3/8" NPT		13	10,3
STEEL	PS - 3,6 / L2	12	700	3,92	2	700	310	230	70	200			3/8" NPT		13	10,3
STEEL	PS - 2,5 / L2	9,5	1400	2,6	2	700	310	230	70	200			3/8" NPT		13	10,3
STEEL	PS - 0,7 / L0,5	7	2000	0,7	0,5	690	225	206	70	168			1/4" GAS		13	8,8
STAINLESS STEEL	PSS - 34	38	35	36,2	-	640	230	110	50	60	94	44	3/8" NPT	1/4" GAS	M8	7
STAINLESS STEEL	PSS - 17	26	105	17,87	-	640	230	110	50	60	94	44	3/8" NPT	1/4" GAS	M8	5,7
STAINLESS STEEL	PSS - 9	19	210	9,92	-	640	230	110	50	60	94	44	3/8" NPT	1/4" GAS	M8	5,3
STAINLESS STEEL	PSS - 3,6	12	700	3,92	-	640	230	110	50	60	94	44	3/8" NPT	1/4" GAS	M8	5,3
STAINLESS STEEL	PSS - 2,5	9,5	1400	2,6	-	640	230	110	50	60	94	44	3/8" NPT	1/4" GAS	M8	5,3
STAINLESS STEEL	PSS - 0,7	7	2000	0,7	-	640	230	110	50	60	94	44	1/4" GAS	1/4" GAS	M8	5,3
STAINLESS STEEL	PSS - 34 / L2	38	35	36,2	2	700	310	230	70	200			3/8" NPT		13	12
STAINLESS STEEL	PSS - 17 / L2	26	105	17,87	2	700	310	230	70	200			3/8" NPT		13	10,7
STAINLESS STEEL	PSS - 9 / L2	19	210	9,92	2	700	310	230	70	200			3/8" NPT		13	10,3
STAINLESS STEEL	PSS - 3,6 / L2	12	700	3,92	2	700	310	230	70	200			3/8" NPT		13	10,3
STAINLESS STEEL	PSS - 2,5 / L2	9,5	1400	2,6	2	700	310	230	70	200			3/8" NPT		13	10,3
STAINLESS STEEL	PSS - 0,7 / L0,5	7	2000	0,7	0,5	690	225	206	70	168			1/4" GAS		13	8,8

PDS/PMS H₂O

700 - 4000 bar
40 - 0,5 cm³
oil flow
1,6 l capacity

Series
PDS/PMS H₂O

Hand pumps for use with water, in aluminum and stainless steel



For use with water H₂O



- High pressure hand pumps suitable for use with water H₂O. This choice is a solution that protects the environment and can be used everywhere as the water is completely green.
- Suitable for all applications where contamination with oil is not allowed.
- Two-stage version with first stage 40 cc oil flow for a quick approach. For maximum speed during the operations.
- Pump body integrated pressure relief valve for maximum operator's safety.

- High performance, low weight and excellent ergonomics.
- Integrated pressure gauge connection for direct mounting of the measuring instrument.
- Oil filler cap with integrated vent. Tough pins with trough-holes for fixing to machinery or structures
- Surface treatments to guarantee total reliability in the most difficult environments and maximum duration.

CUSTOM PUMPS ON REQUEST



CUSTOM MADE EQUIPMENT

H₂O version ▶

For years F.P.T. cares of the environment and its protection. It has in fact various products suitable for use with water or fluids, 100% biodegradable.

This type of product is highly appreciated in all those sectors where, for obvious reasons, contamination with chemical and petroleum products is not allowed. Such as test laboratories, marine environment, food, testing, archaeological, restorations.

Manufacturable products range over stainless steel hydraulic cylinders, valves, hand pumps, stainless steel couplers and electric or pneumatic pumps. It is also possible to design and produce systems and equipment on customer specifications.

MODEL	PRESSURE	OIL FLOW	RESERVOIR	USABLE	DIMENSIONS in mm										WEIGHT
	1 ST /2 ND STAGE	1 ST /2 ND STAGE	CAPACITY	OIL	A	B	C	D	E	F	G	H	M	P	kg
	bar	cm ³	litres	litres											
PDSA-40 H ₂ O	25/700	40/3	1,8	1,6	590	477	435	200	130	130	102	3/8" NPT	13	G 1/2"	7,8
PDSA 1600 H ₂ O	25/1600	40/1	1,8	1,6	577	588,5	436	200	130	130	102	1/4" GAS	13	1/2" GAS	7,8
PDSA 3000 H ₂ O	16/3000	40/0,5	1,8	1,6	577	588,5	436	200	130	130	102	3/4"-16 UNF	13	9/16"-18 UNF	7,8
PMS 4000 H ₂ O	4000	0,5	1,8	1,6	577	588,5	436	200	130	130	102	9/16"-18 UNF	13	9/16"-18 UNF	7,8

